

Top Loading Arm – E2611

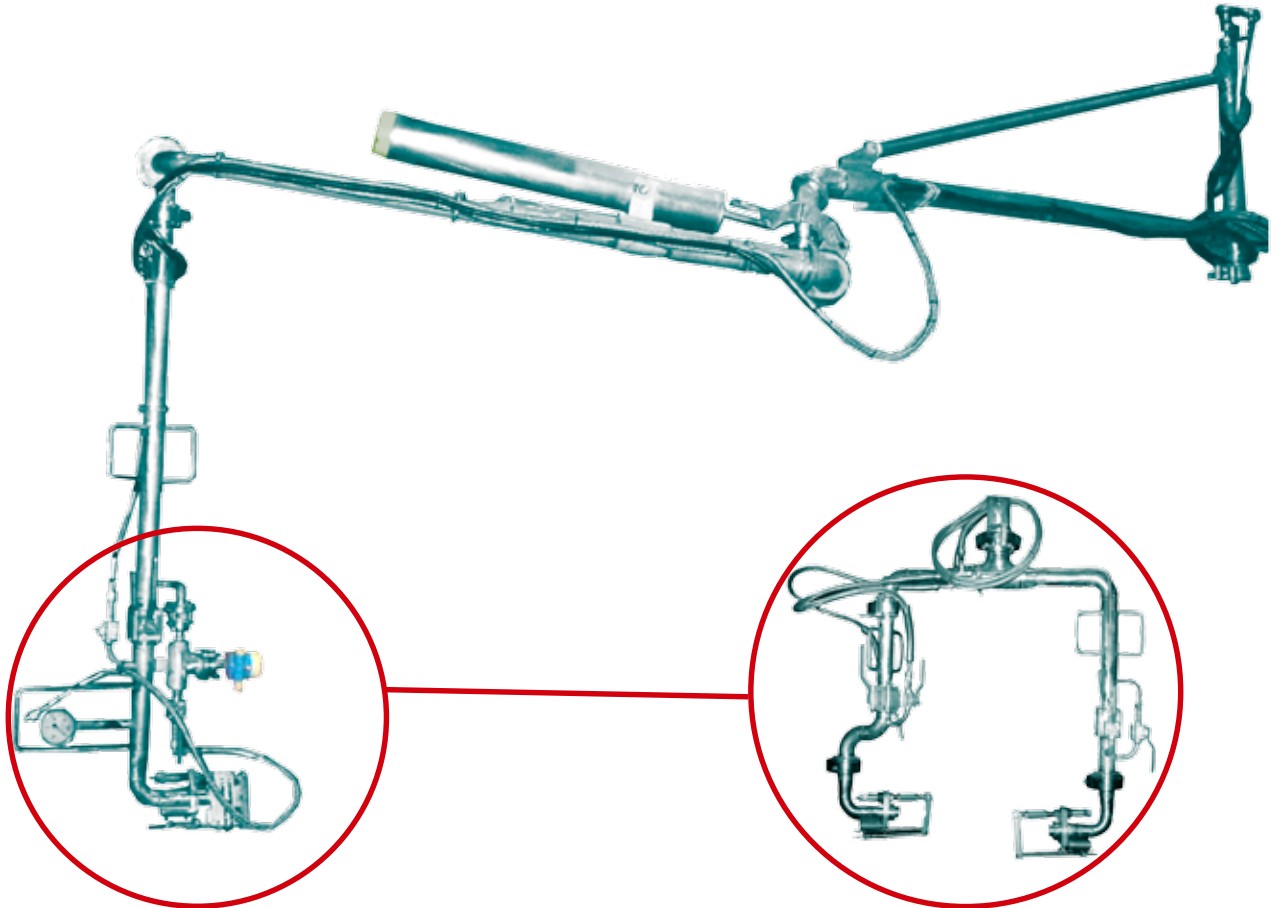

These Top Loading Arms are especially designed for loading and unloading of liquefied gases.

The arm is connected to the vessel by couplers, especially designed for Russian railcars. Due to the coupler a fast and safe connection to the valves of the vessel is provided.

- for liquid gas
- for loading and unloading of Russian Railcars
- easy handling
- low maintenance
- long life
- environmentally friendly
- EMCO-high performance swivel joints

E2611

Dimensions and technical data

Technical data

Sizes	Material	Seals	Temperature range
DN 100, 80, 50, 40	carbon steel / stainless steel	PTFE special materials	-57 °C to +110 °C,

Alternative dimensions and materials on request

Typical application:

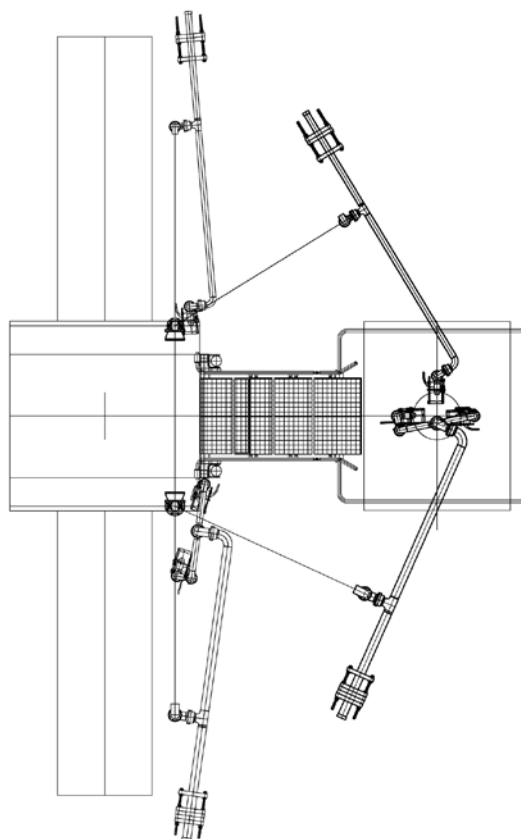
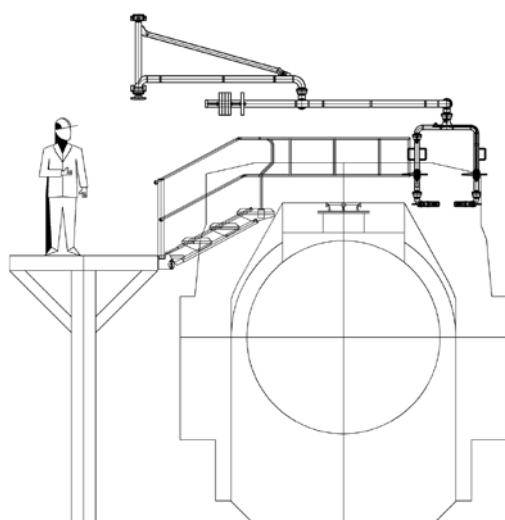

The Loading arm E2611 is combined by a second recommended reach loading arm:

- The Loading arm is designed with two end pipes for unloading
- Gas return arm with one end pipe allows another use of unloading the vessel under pressure

The robust and high quality design of the swivel joints and the spring cylinder balancing gives comfortable and smooth handling of the arm.

The E2611 presents an economic and successful solution for selected applications of loading and unloading liquified hydrocarbon gases. In distinction to hoses the piping provides safety from explosion, driveway obstructions and condensate losses at site.

EMCO WHEATON carbon steel swivel joint with flame hardened ball race way for a long life time!

For more details see our data sheet swivel joint D2000.



Fluid Transfer Division

EMCO WHEATON

A Gardner Denver Product

Whilst the content of this leaflet has been edited with the greatest care, we are not liable for any errors and/or omissions. Subject to change without notice.

EMCO WHEATON GmbH
Emcostraße 2-4 · 35274 Kirchhain · Germany
Phone +49 6422 84-0 · Fax +49 6422 5100
www.emcowheaton.com · info-de@emcowheaton.com