

Sarasota FD910 Sarasota FD930 Sarasota FD950 Sarasota FD960

Liquid Density Meters for General Industrial, Hygienic, Chemical, and Fiscal Applications

The Sarasota range of liquid density meters measures density or density related variables within the oil and gas, petrochemical, chemical, food and beverage and general process industries. These high accuracy online continuous meters provide key information for process monitoring and control, quality control, product interface detection, and custody transfer applications.



Features

- Continuous, online density monitoring
- Measurement at process conditions
- Straight through flow path
- Materials to suit applications
- Compact and lightweight, easy to install
- Hazardous area approvals
- Converter electronics to suit application

Process optimization and product quality control are achieved through the close control of process parameters and final product quality. The composition of any liquid or slurry is often characterized by its density or specific gravity. The continuous and accurate monitoring of this density, or a density related variable, will detect any variation of process constituents or final product quality in near real time, allowing improved productivity, minimized product wastage and reduced costs when compared to sampling methods.

Thermo Electron Corporation's Sarasota range of liquid density meters is designed for the oil and gas, petrochemical, chemical, food and beverage and general industrial

markets, with output variables such as specific gravity, % concentration, °Brix, °API, °Baume, line density, or referred density being provided either by a third party flow computer or by a Sarasota density converter. The Sarasota HME900 field mounted density converter option provides a direct HART® compatible output, whereas the Sarasota CM200 panel mounted electronics unit provides a critical input into a plant's optimization system, quality and quantity control system, or metering control system.

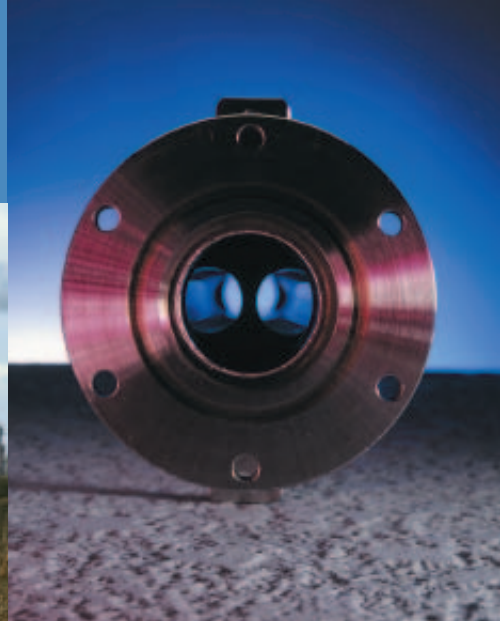

General Features of the Range

The Sarasota liquid density meters are of the proven vibrating element design which is widely accepted as the most accurate method of continuous, online density measurement and is therefore particularly suitable for fiscal/custody transfer duties. Several design features ensure improved repeatability and accuracy, contributing to the high integrity of the measurement. Thermo's twin tube design is inherently more stable than single tube technology and an integral, high grade PT100 temperature element within the instrument allows compensation of the density meter for temperature effect and may be used for compensation to reference conditions.

Compact and lightweight, the density meters are particularly immune to plant vibration and in most cases, can be installed directly into existing pipework without the need for upstream flow conditioning, instrument supports, or pipeline clamps. Installation may be in any plane within the specified flow rates, and is quick and simple with minimal pipeline disturbance or process downtime.

The straight through sensor offers an unobstructed flow path to ensure minimal pressure drop, higher flow rates, and the ability to inspect and clean the instrument if required. A choice of wetted parts and sensor materials is offered including Hastelloy® C276 for improved corrosion resistance, Ni-Span C® for its low temperature coefficient for fiscal applications, and stainless steel for hygienic or general industrial use.

With hazardous area approvals on all models and secondary containment on the industrial, chemical and fiscal models, the instruments are suitable for use in most hostile environments.

Density Converter Electronics

A choice of density converter solutions offers end users full flexibility in the processing of the measurement data to best suit the application.

A field mounted, Sarasota HME900 headmounted electronics unit conditions the output signal to give a HART compatible 4-20 mA output that can then be interrogated by any HART system. An optional local display on the Sarasota HME900 allows the process engineer to view the prime variable value either in engineering units alone, or with an alternating display of percent of chosen span.

Alternatively, the frequency and PRT (RTD) outputs from the density meter may be taken to a third party flow computer or remote Sarasota CM200 density converter. The Sarasota CM200 is a versatile unit that can be configured as required depending on the input/output requirements of the end user's application. The unit performs calculations to give the required density or density derived parameter.

Full information about the density converters is available in the Sarasota HME900 and Sarasota CM200 density converter specification sheet.

Thermo's Applications Expertise

Thermo has over 30 years applications expertise within the oil and gas, petrochemical, chemical, food and beverage, and pharmaceutical industries. The ability to infer density related variables such as specific gravity, % concentration, °Brix, °API, °Baume, line density or referred density has led to an extensive range of applications from product identification and product quality control to system metering and custody transfer.

With a choice of wetted parts materials, the optimum choice of model to suit the application can be made. The stainless steel Sarasota FD910 suits a broad range of general industrial applications and the Sarasota FD930 has been specifically designed for hygienic applications. The Sarasota FD950 Hastelloy C276 version is more corrosion resistant and can be used in chemical or aggressive applications, and the Sarasota FD960 Ni-Span C fiscal model gives superior performance in the measurement of high value products such as liquid hydrocarbons.





Applications

- Blending
- Product identification
- Interface detection
- Dilution measurement
- Process/quality control
- SG measurement
- Process efficiency
- Waste minimization
- Product consistency
- Volumetric to mass flow metering systems

Sarasota FD910 / Sarasota FD950 / Sarasota FD960



The Sarasota FD910 for Industrial Applications

With its stainless steel construction, the Sarasota FD910 industrial density meter is best suited to those general process applications that do not require the specialist materials offered by the other models in the range. The Sarasota FD910 meets the demands of many process monitoring and control applications in a vast number of industries.

The Sarasota FD930 for Hygienic Applications

The Sarasota FD930 hygienic density meter is designed for the measurement of homogeneous Newtonian liquids, creams, slurries and coagulates within the dairy, food and beverage, and pharmaceutical industries.

Typical applications include product identification, product blending, recipe management, fermentation control, milk product manufacture, and confectionery and tablet coating.

With its stainless steel, straight through design, TriClamp® pipeline fittings and CIP design, the Sarasota FD930 is suitable for all hygienic applications including those where 'clean in place' procedures are required.

The Sarasota FD930 allows near-laboratory accurate density measurements to be made at process pressures and temperatures. The continuous nature of the measurement allows 'real time' correction of process errors to be undertaken without the need for manual sampling which optimizes recipe management and minimizes sub-standard product.

Sarasota FD930



The Sarasota FD950 for Chemical Applications

The wetted parts of the Sarasota FD950 are made of Hastelloy C276 making it the most corrosion resistant option of the range. With aggressive applications throughout the petrochemical, chemical, and pharmaceutical industries, the Sarasota FD950 is often the preferred choice.

The Sarasota FD960 for Fiscal/Custody Transfer Applications

As high value products, liquid hydrocarbons must be identified and measured as accurately and as quickly as possible to minimize product wastage and determine custody transfer responsibilities.

The Sarasota FD960 fiscal density meter has been applied to multi-product pipeline metering, custody transfer and interface detection systems throughout the world. The use of Ni-Span C wetted parts with its low temperature coefficient allows the Sarasota FD960 to offer superior accuracy with minimal pressure drop.

Typical applications include product blending, batch control, dilution measurement, product identification, interface detection and tanker loading.



Calibration and Service:

The calibration of the liquid density meters is undertaken in-house on a calibration rig that is traceable to national standards. Supporting documentation is available including a traceable equipment list.

For most applications, installation is straightforward, on-site calibration is generally unnecessary and the instruments are usually maintenance-free. However, Thermo's dedicated service team offers an installation, commissioning, maintenance, and repair service for the liquid density meter range and associated electronics. On-site visits, in-house repairs and maintenance contracts can be arranged as required.

Sarasota FD910 / Sarasota FD950 / Sarasota FD960 Dimensional Diagram

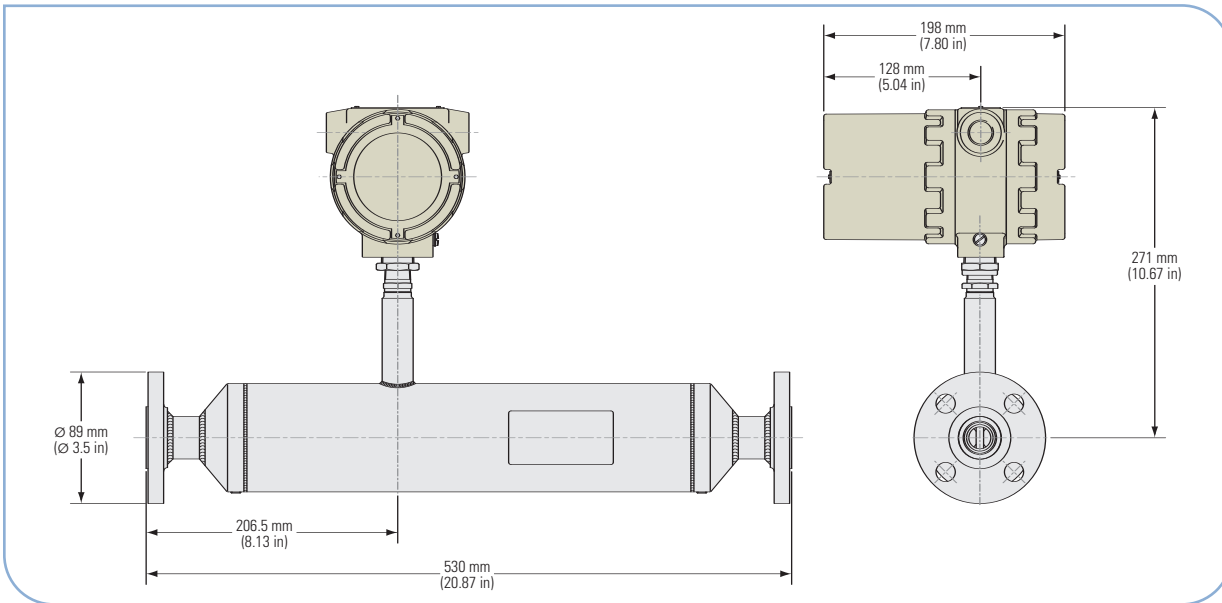

Sarasota FD930 Dimensional Diagram

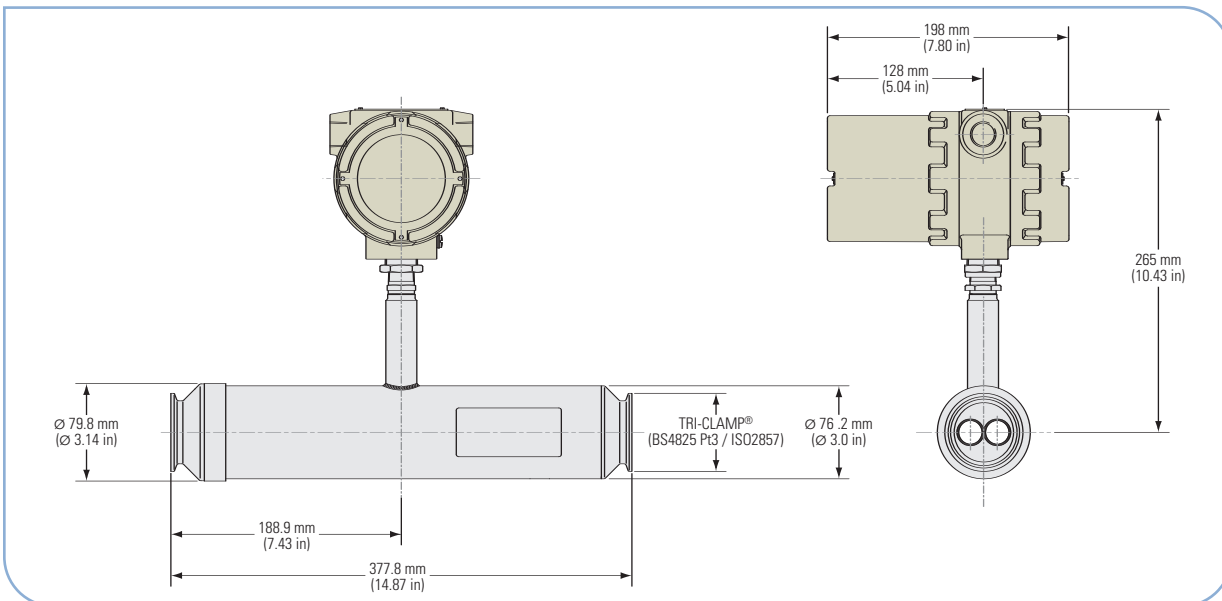

Trim this page short (7.625 inches) to accommodate potential hole punching by end users

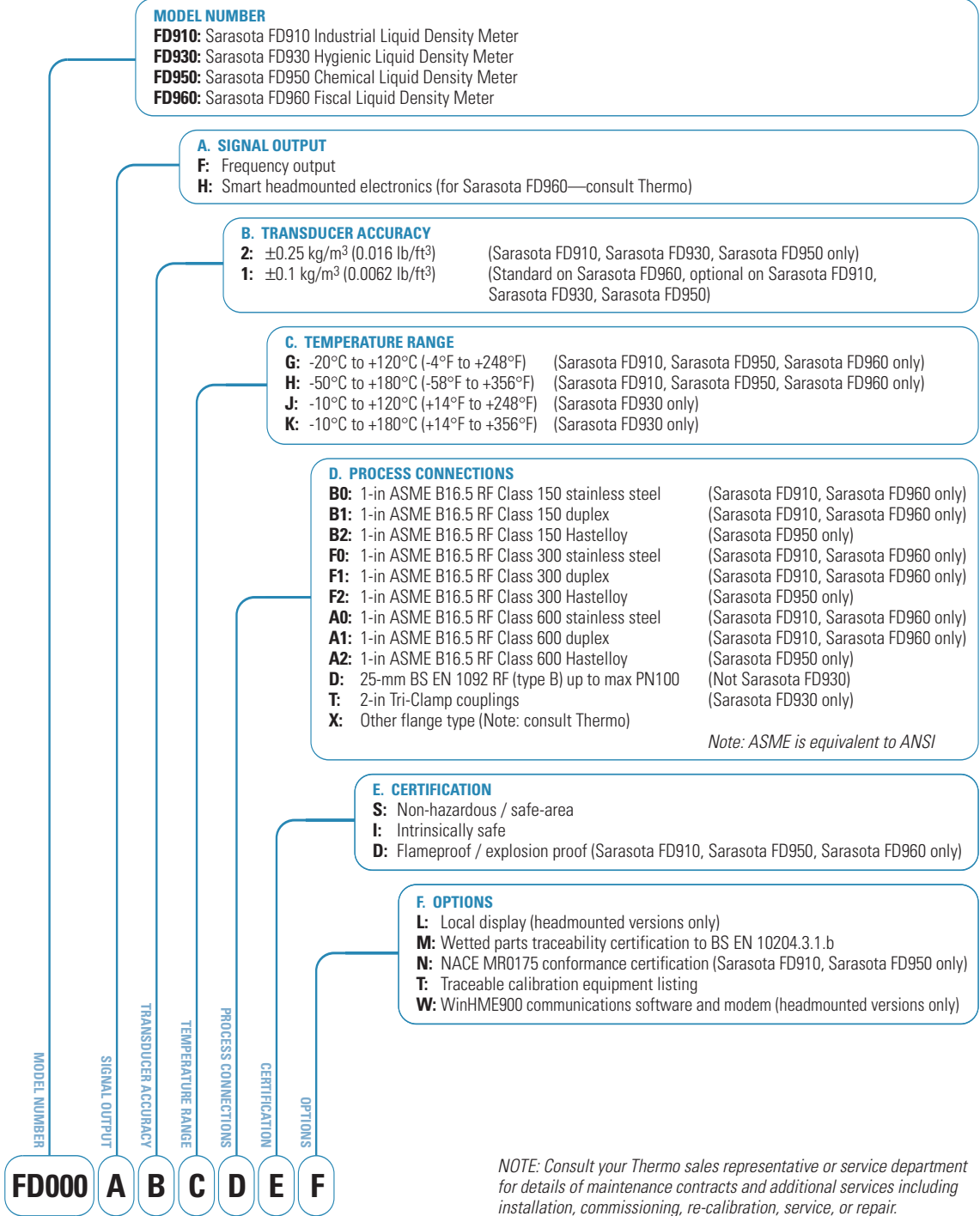

Sarasota Liquid Density Meters

Specification	
Functional Specifications	
Transducer Calibration Accuracy	Available to $\pm 0.1 \text{ kg/m}^3$ ($\pm 0.0062 \text{ lb/ft}^3$)
Repeatability	0.02 kg/m^3 (0.0012 lb/ft^3)
Flow Range	Vertical installation: 0 l/min to 300 l/min (0 USG/min to 79 USG/min); Horizontal installation: 5 l/min to 300 l/min (1.3 USG/min to 79 USG/min)
Operating Density Range	0 kg/m^3 to 2100 kg/m^3 (0 lb/ft^3 to 131.1 lb/ft^3)
Installation	Vertical installation (standard), horizontal installation (optional); No instrument or pipework supports required Sarasota FD930 only: self draining up to 45° from vertical
Pressure Effect (corrected)	$0.003 \text{ kg/m}^3/\text{bar}$ ($0.00013 \text{ lb/ft}^3/\text{psi}$) note: correction coefficients applied
Temperature Effect (corrected)	$0.005 \text{ kg/m}^3/^\circ\text{C}$ ($0.0002 \text{ lb/ft}^3/^\circ\text{F}$) note: correction coefficients applied
Density Meter Dimensions	See dimensional diagrams
Shipping Dimensions	Sarasota FD910 / FD950 / FD960: 590 mm x 390 mm x 290 mm (approx 24 in x 16 in x 12 in) Sarasota FD930: 440 mm x 360 mm x 270 mm (approx 18 in x 14 in x 11 in)
Net Weight	Sarasota FD910 / FD950 / FD960: 11 kg (24 lb); Sarasota FD930: 5.5 kg (12 lb)
Shipping Weight	Sarasota FD910 / FD950 / FD960: 15 kg (33 lb); Sarasota FD930: 10 kg (22 lb)
Environmental Rating	IP65 (NEMA 4X)
Electrical Connections	Screw terminals; Cable entry: 2 x $\frac{3}{4}$ -in NPT
Temperature Measurement	High accuracy $\frac{1}{2}$ DIN integral 4-wire PT100
Local Display (H option)	$4\frac{1}{2}$ -digit 7.6 mm (0.3 in) 7-segment LCD display. Resolution 0.1% or 0.01% depending on display variable.
Secondary Containment	As flange rating to Class 300 then 2.5 times maximum safety flange rating to Class 600
Factory Calibration Range	650 kg/m^3 to 1600 kg/m^3 (40.58 lb/ft^3 to 99.98 lb/ft^3)
Operating Temperature Range	-20°C to $+60^\circ\text{C}$ (-4°F to $+140^\circ\text{F}$) ambient
Process Temperature Range	Sarasota FD910 / FD950 / FD960: -50°C to $+180^\circ\text{C}$ (-58°F to $+356^\circ\text{F}$); Sarasota FD930: -10°C to $+180^\circ\text{C}$ ($+14^\circ\text{F}$ to $+356^\circ\text{F}$)
Output	F option (frequency output): Frequency related to density on 2-wire current modulated loop 6 mA to 18 mA; 4-wire PT100 H option (headmounted electronics): Analog 4-20 mA related to density or density derived variable; HART protocol
Power Supply	F option (frequency output): 13-28 VDC 10 mA average (peak 18 mA) H option (headmounted electronics): 2 x 13-28 VDC 25 mA; 4-20 mA current pressure input available
Maximum Operating Pressure	Sarasota FD910 / FD950 / FD960: as flange rating; Sarasota FD930: 10 bar (145 psi)
Material Specifications	
Sensor	Sarasota FD910 / FD930: stainless steel (316L / 1.4404); Sarasota FD950: Hastelloy C276; Sarasota FD960: Ni-Span C
Other Wetted Parts	Sarasota FD910 (Class 150, 300) / FD930 / FD960: 316L stainless steel (316L / 1.4404) Sarasota FD910 (Class 600) / FD950: Hastelloy C276
Case	Stainless steel (316L / 1.4404)
Electronics Housing	Copper free aluminium grey epoxy finish; Plate glass window for local display option
Process Connections	
1-in ASME B16.5 RF (raised face)	Sarasota FD910 / FD960: stainless steel (316L / 1.4404) – Class 150, 300 or 600 Sarasota FD910 / FD960: duplex (A 182 Gr.F51) – Class 150, 300 or 600 Sarasota FD950 only: Hastelloy C276 – Class 150, 300 or 600
Note: ASME is equivalent to ANSI	
25-mm BSEN1092 RF (raised face - type B)	Sarasota FD910 / FD950 / FD960: Up to maximum PN100
2-in Tri-clamp Couplings	Sarasota FD930 only
Other Flange Types	Consult Thermo
Compliance/Certification	
Quality Assurance	ISO 9001:2000
CE mark	Compliant
Electromagnetic Compatibility	Compliant (EN 61326:1997)
Pressure Equipment Directive (97/23/EC)	Sarasota FD910 / FD950 / FD960: category III; Sarasota FD930: SEP (sound engineering practice)
Low Voltage Directive	Compliant
Safe Area Use	As standard
BS EN ISO 15156 / NACE MR0175	
Conformance	Available on Sarasota FD910 and Sarasota FD950 only
ATEX Conformance: Intrinsically Safe (94/9/EC)	F option (frequency output): Ex II 1 G EEx ia IIC T6 ($-20^\circ\text{C} \leq T_a \leq +60^\circ\text{C}$) H option (headmounted electronics): Ex II 1 G EEx ia IIC T4 ($-20^\circ\text{C} \leq T_a \leq +60^\circ\text{C}$)
ATEX Conformance: Flameproof (94/9/EC)	Sarasota FD910 / FD950 / FD960 only: Ex II 2 G EEx d IIC T4 ($T_{amb} = -20^\circ\text{C}$ to $+60^\circ\text{C}$) or T3 ($T_{amb} = -20^\circ\text{C}$ to $+60^\circ\text{C}$) Temperature classification of T4 or T3 for use with maximum process fluid temperature of $+115^\circ\text{C}$ or $+180^\circ\text{C}$ respectively
Canadian Standards Association (CSA)	Sarasota FD910 / FD950 / FD960 only: Explosion proof Class 1, Groups B,C, and D
Hygienic Authorization	Sarasota FD930 only: designed to meet 3As sanitary standards
Calibration Certification	Calibration traceable to national standards. Calibration certificates supplied as standard. Optional traceable calibration equipment listing available
Material Traceability	Wetted parts traceability to BS EN 10204.3.1.b; Certification available

©2005 Thermo Electron Corporation. All rights reserved. HART is a registered trademark of the HART Communication Foundation. Tri-Clamp is a registered trademark of Tri-Clover, Inc. Hastelloy is a registered trademark of Haynes International, Inc. Ni-Span C is a registered trademark of the Special Metals Corporation. Specifications, terms and pricing are subject to change. Not all products are available in all countries. Please consult your local sales representatives for details. Literature Code PI.2024.0705

Room 1010 - 1019
Ping'an Mansion No. 23 Jinrong Street
Xicheng Dist, Beijing, CHINA 100032

Ion Path, Road Three, Winsford
Cheshire CW7 3GA UK

9303 W. Sam Houston Pkwy. S.
Houston, TX 77099 USA

+86 (10) 5850-3588
+86 (10) 6621-0847 fax

+44 (0) 1606 548700
+44 (0) 1606 548711 fax

+1 (800) 437-7979
+1 (713) 272-4573 fax

Process Instruments

www.thermo.com
sales.process@thermo.com